

SIGHT CHECKERS SCKi

DESCRIPTION

The ADCA SCKi sight checkers function as both sight glasses and check valves.

Such devices are designed for installation downstream of steam traps, to monitor their performance, while also working as reliable check valves to prevent condensate backflow.

USE: Condensate lines, downstream of steam traps.

AVAILABLE MODELS: SCKi – stainless steel.

SIZES: 1/2" to 1".

CONNECTIONS: Female threaded ISO 7 Rp or NPT.

INSTALLATION: Horizontal or vertical (bottom to top) installation. See IMI – Installation and maintenance instructions. The SCKi should be fitted at least 1 meter away from the trap, in order to protect the glass from thermal pressure or shock.

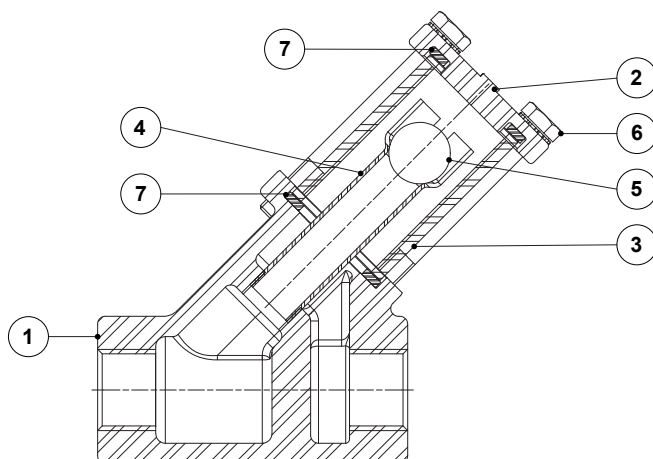
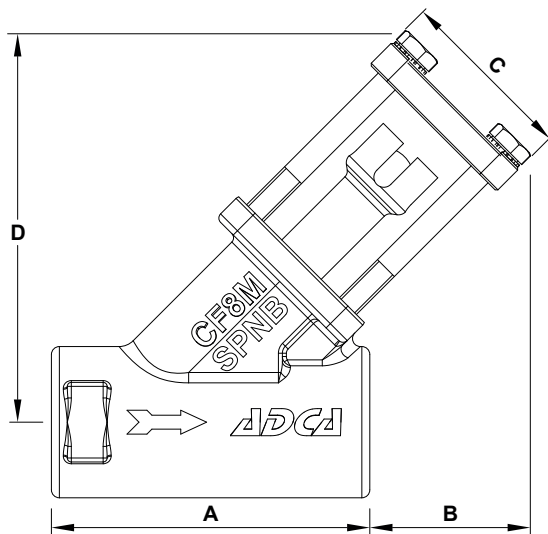

CE MARKING – GROUP 2 (PED – EUROPEAN DIRECTIVE)	
PN 10	CATEGORY
1/2" to 1"	SEP

LIMITING CONDITIONS	
PMO – Maximum operating pressure	10 bar
TMO – Maximum operating temperature	150 °C

DIMENSIONS (mm)					
SIZE	A	B	C	D	WGT. (kg)
1/2"	80	36	45	95	0,9
3/4"	80	36	45	95	0,9
1"	90	40	56	110	1,3

MATERIALS		
POS. No.	DESIGNATION	MATERIAL
1	Body	A351 CF8M / 1.4408
2	Cover	A351 CF8M / 1.4408
3	* Sight tube	Borosilicate glass
4	Discharge tube	Copper
5	Check ball	Stainless steel
6	Bolt	Stainless steel A2-70
7	* Gasket	Graphite

* Available spare parts.